



A TEC Advanced Process Technologies GmbH

Kasernstrasse 16-18
3500 Krems
AUSTRIA

Tel.: +43 2732 75680
Fax: +43 2732 75680 15
E-Mail: sales@atec-ltd.com

www.atec-ltd.com

Please note:

In the following article, A TEC Advanced Process Technologies GmbH could be mentioned also as PMT, PMT-Zyklontechnik GmbH or Zyklontechnik GmbH (=company's name before 1st June 2005).

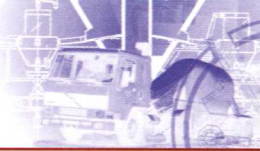

The HURRICLON® reaches 99% efficiency

Dipl.-Ing. Gerald Reither, PMT-Zyklontechnik GmbH

Cementos RIOCLARO is a cement plant in the middle of Colombia in the large area of Medellin. The plant runs two dry kilns. One kiln has a capacity of 1,700tpd and four-stage preheater tower, the second kiln has a capacity of 2,100tpd and five-stage preheater tower. Both kilns are equipped with clinker coolers of the grate cooler type.

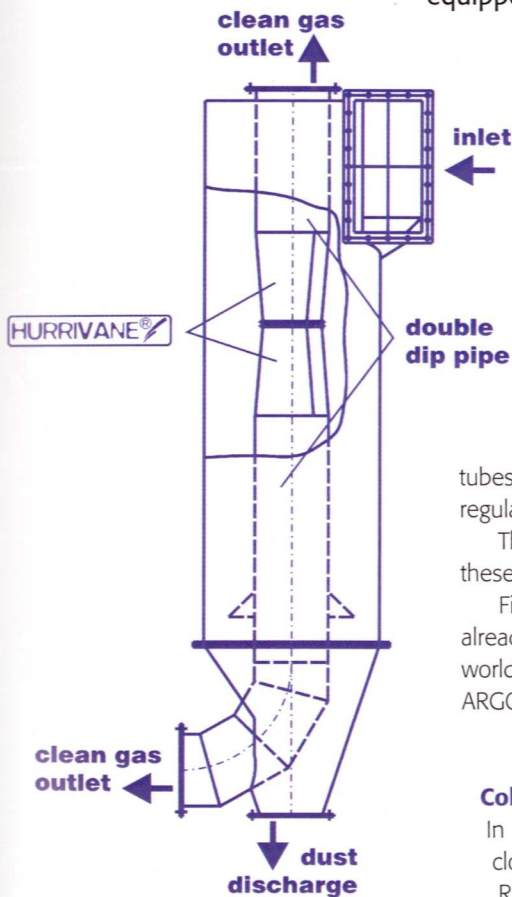

The dedusting of the exhaust air of both clinker coolers was done with multicyclones. There was no additional dedusting after the multicyclones and the efficiency of the systems was very low.

Because of the low efficiency of the systems, Cementos RIOCLARO was facing a serious problem of dust emission from the clinker cooler dedusting.

The situation eventually became so complicated that production personnel had to reduce the performance of the system to control the amount of emission from the clinker cooler.

Additionally there was very high wear detected in the impeller of the exhaust-air fans, as well as in the small tubes of the multicyclones themselves, which caused very costly and regular maintenance and repair work.

Therefore, in early 2000 RIOCLARO started to search for solutions for these operational and environmental problems.

Finally RIOCLARO found the solution in the HURRICLON® which has already proven its performance at several similar installations all over the world, including at Colclinker, which is one of the cement plants of the ARGOS Group.

Colclinker Problems Solved

In 1999 Colclinker, which is located in the Caribbean area of Colombia close to Cartagena Bay, had been facing a situation very similar to RIOCLARO. At Colclinker there were also multicyclones in operation to dedust the exhaust air of the clinker coolers and the same problems with high dust emissions and high wear had occurred.

In 1999 Colclinker decided to replace the existing multicyclone of kiln 3 – the line with the highest emissions – with HURRICLON® made by PMT-Zyklontechnik GmbH from Austria. PMT installed a package of four HURRICLON® units for a gas quantity of 90,000 Am³/h at 250°C.



The HURRICLON® Technology

The HURRICLON® is a cyclone with two dip-tubes including Vortex Finder Vanes – so-called HURRIVANE®.

The HURRICLON® provides an improved separation efficiency and a lower pressure drop compared to common cyclones and therefore is the optimum installation for applications



	Before modification	Multicyclone after HURRICLON
Separation efficiency	50,3%	99%
Dust emission	550 kg/h	45 kg/h
Pressure drop	750 Pa	580 Pa
Production	2,100 tpd	2,115 tpd

Table 1: HURRICLON® performance for dedusting of clinker cooler exhaust dust

where common cyclones or multicyclones are at their limit, either in separation or pressure drop.

As part of the project at Colclinker, the installation of HURRICLON® was evaluated and compared to solutions with Electrostatic Precipitators and Baghouses.

The investment cost for HURRICLON® was only 20% of a baghouse installation and the HURRICLON® provided significant additional advantages in maintenance costs. The installation of an ESP would have been seven times more costly and both ESP and Baghouse would consume more energy and a lot more space in the plant. Finally the HURRICLON® was found to be the most economic and fastest installation among all options.

The results after the installation of HURRICLON® proved that it was the right direction to go in:

- The dust emissions were reduced to 167mg/Nm³ which was a quarter of the previous value.
- Additionally, the energy consumption at the fan was reduced by 15% because of the reduced pressure drop.

The Installation at Cementos RIOCLARO

In the summer of 2000 Cementos RIOCLARO ordered HURRICLON® – firstly for replacing the multicyclone of kiln two, the larger line.

In cooperation with PMT-Zyklontechnik a

solution was worked out which uses as much as possible of the existing equipment such as rotary valves, screw conveyors, and the existing fan and stack. PMT designed a package of six HURRICLON® units for a gas quantity of 201,700Am³/h at 350°C.

Due to the low space requirements the HURRICLON® could be installed within the space of the former multicyclone.

The engineering of the ducting system to and from the HURRICLON® was done by a Colombian engineering company with periodical checks by PMT-Zyklontechnik GmbH. The manufacturing of the ducting and the housing of the HURRICLON® was done locally.

The Results

The results of the analysis in the inlet duct and stack discharge performed by RIOCLARO are shown in Table 1 above.

Conclusion

Once again the HURRICLON® with its separation efficiency of 99%, has proven to be the most economic and effective way to significantly reduce the dust emissions after a clinker cooler.

But the HURRICLON® provides not only a solution to protect the environment, it also protects it against wear. Additionally the HURRICLON® offers a reduction in energy consumption at the fan because of reduced pressure drop – a 22.6% reduction at RIOCLARO.

Considering the significantly improved separation efficiency, the installation of HURRICLON® at RIOCLARO even provides an increase of production by collecting 15tpd additional clinker dust.

In the meantime, the ARGOS group has ordered HURRICLON® for clinker cooler dedusting in a further seven lines and also has projects with PMT-Zyklontechnik for other applications in their plants such as preheater towers, raw mills and cement mills. ■

